

REV	DATE	DESCRIPTION	DRAWN

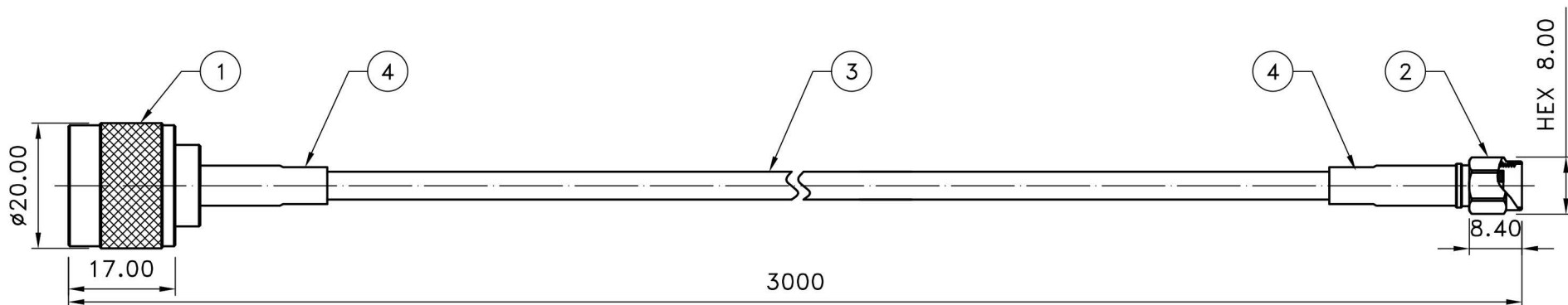

NOTE:

- 1.N MALE CRIMP
 CENTER PIN GOLD PLATING 3μ THICK OVER NICKEL STRIKE
 BODY NICKEL PLATING 70μ THICK OVER NICKEL STRIKE
 BRASS AND PTFE PER SGS
 FINISH PLATING THICKNESS IN MICRO-INCHES
 COPPER PARTS AUTOMATIC CNC MANUFACTURING
- 2.RP SMA MALE CRIMP
 CENTER PIN GOLD PLATING OVER NICKEL STRIKE
 BODY GOLD PLATING OVER NICKEL STRIKE
 BRASS PER JIS-C3604
 PTFE PER ASTM D1457 AND ASTM D1710
 FINISH PLATING THICKNESS IN MICRO-INCHES
 COPPER PARTS AUTOMATIC CNC MANUFACTURING
- 3.LOW LOSS 200 COAXIAL CABLE/3D
 ATTENUATION : 0.32dB/m@900MHz 0.42dB/m@1800MHz 0.61dB/m@3000MHz
 CONDUCTOR : BARE COPPER WIRE/Ø1.12mm
 INSULATION : GAS-FPE/Ø2.95mm
 TAPE : BONDED ALUMINUM FOIL
 SHIELD : TINNED COPPER WARE/16*4*0.10mm/59% COVERAGE
 JACKET : PVC/Ø4.95mm

Prohibit re-circulating



4	D0176 (SHRINK TUBE)	PE	BLACK	2
3	LLC200	ASSY	BLACK	1
2	SMA-1001-39-F2-RP-TGG	BRASS	GOLD	1
1	N-1101-4-F2-TGN	BRASS	NICKEL	1
NO	DESCRIPTION	MATERIAL	FINISH	Q'ty

NOTE	DIMENSION
1.STRIP ALL BURRS. 2.ALL DIMENSIONS ARE AFTER PLATING. 3.DIAMETERS ON COMMON CENTERS. TO BE CONCENTRIC WITHIN 0.1 T.I.R 4.CHAMFER 1ST & LAST THREADS 45° 5.BREAK ALL CONNERS & EDGES CO.15 MAX.	UNLESS OTHERWISE NOTED TOLERANCES 0.X=±0.2 0.XX=±0.1 CABLE LENGTH: L ≥10000=+50 1000≤L<10000=+30 L<1000=+8

 WIFI-Link™ 台灣威海尼可	
TITLE N male to RP SMA male	
DRAWING NO. np-rsmap-200-3.0	
APPROVED	DRAWN DATE 11/24/16
CHECKED	SCALE 1:1
DRAWN ALICE	UNIT mm